

# PRINCIPLES OF OPERATING SYSTEMS

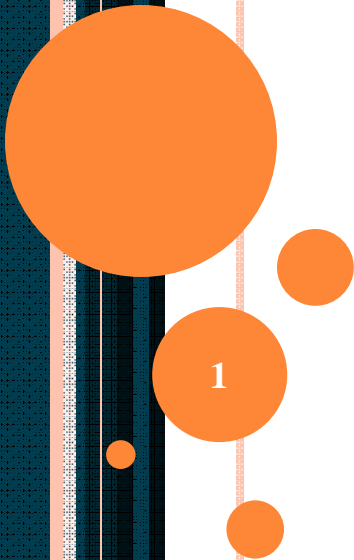

# Operating System

## LECTURE-2

***OPERATING SYSTEM FUNCTIONS &  
MULTITASKING & MULTIPROCESSING OS***

# Software

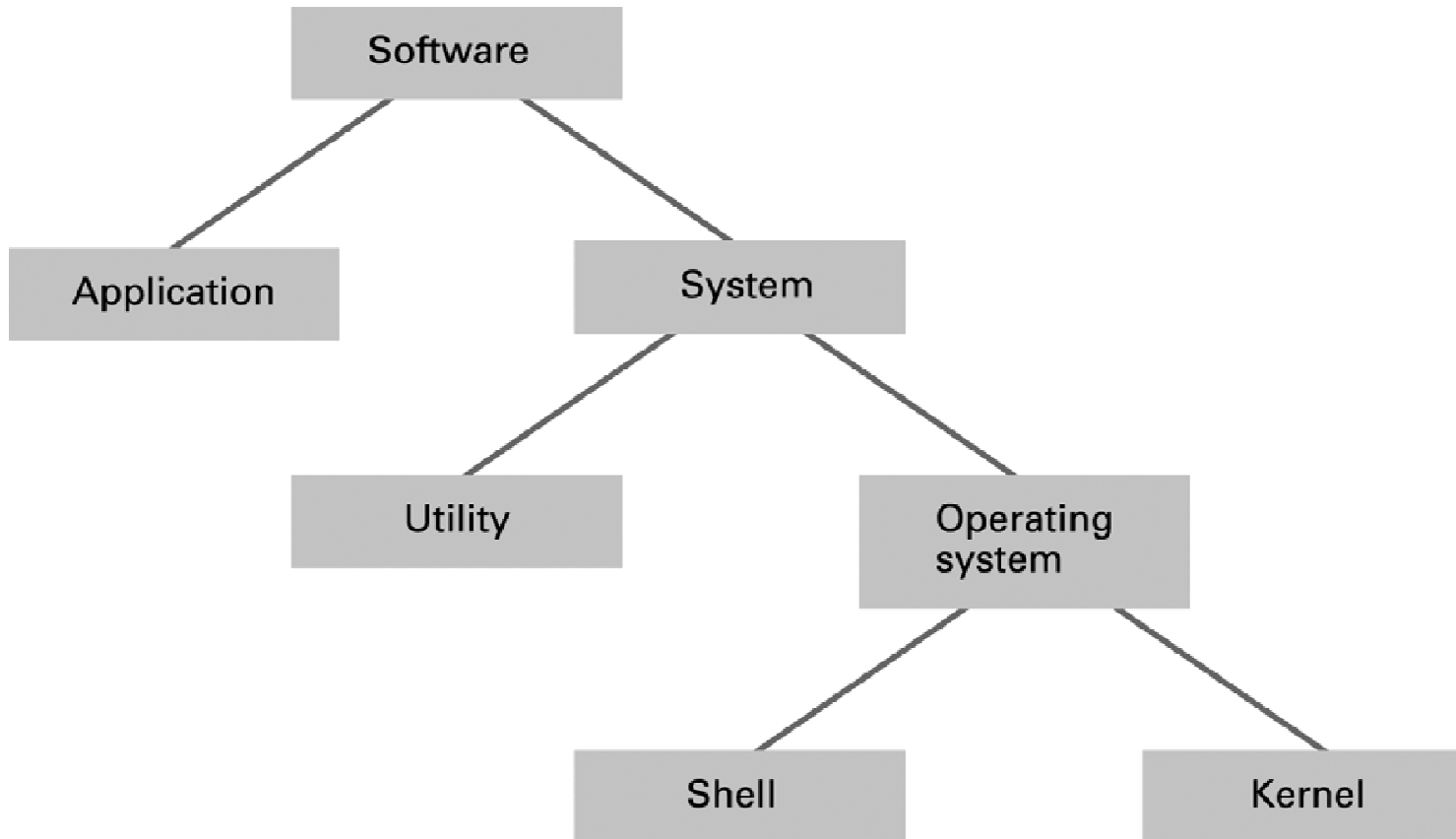

# Software

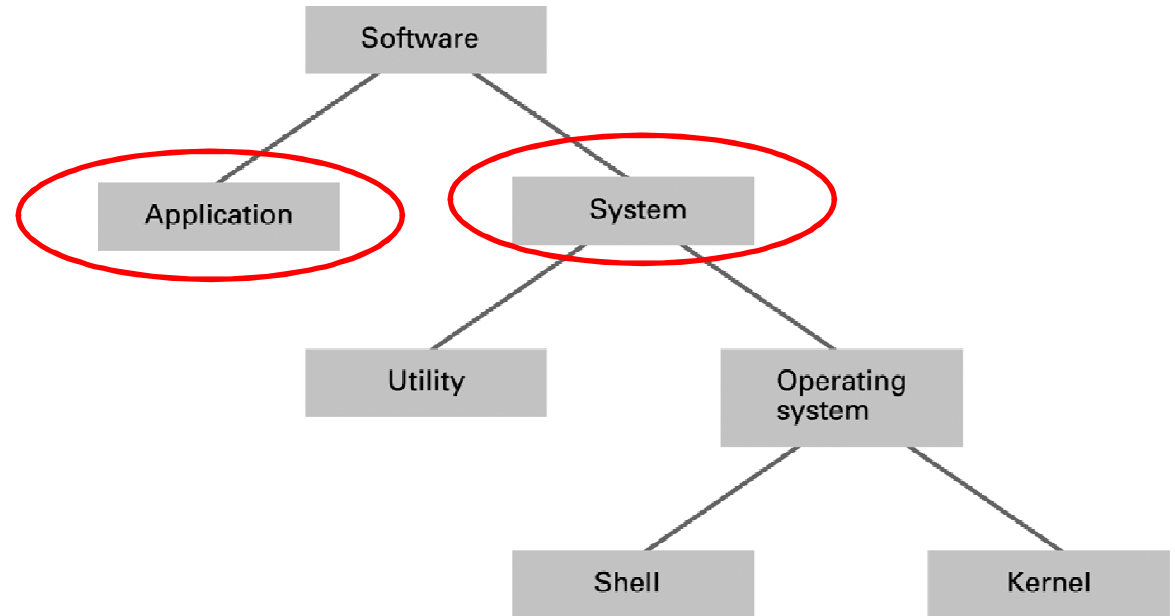

- **Application software:** Programs for performing a specific task
  - Word processing, spreadsheets, gaming, web page design, graphic design
- **System software:**
  - **Operating software:** Software that controls the overall operation of the computer
    - (more next)
  - **Utility software:** Software that extends or customizes the capabilities of the operating system
    - Formatting
    - compress/decompress data
    - network communications
- Distinction between Application and System software can be vague.
  - Anti-trust and unfair business practice lawsuits against Microsoft have been filed over the years.



# Operating System Software

- **Operating System (OS)** – Software that controls the overall operation of a computer

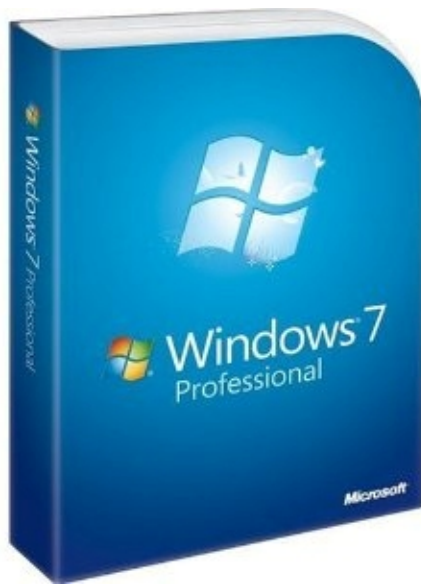

# What is an operating system (OS)?

## Operating System Software

Software which manages the overall operation of the computer system including:

- hardware (CPU, RAM, I/O)
- security
- system interface
- application interface

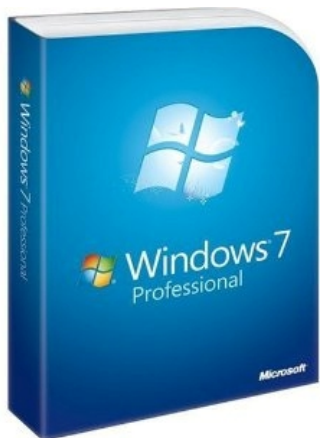

# What is an operating system (OS)?

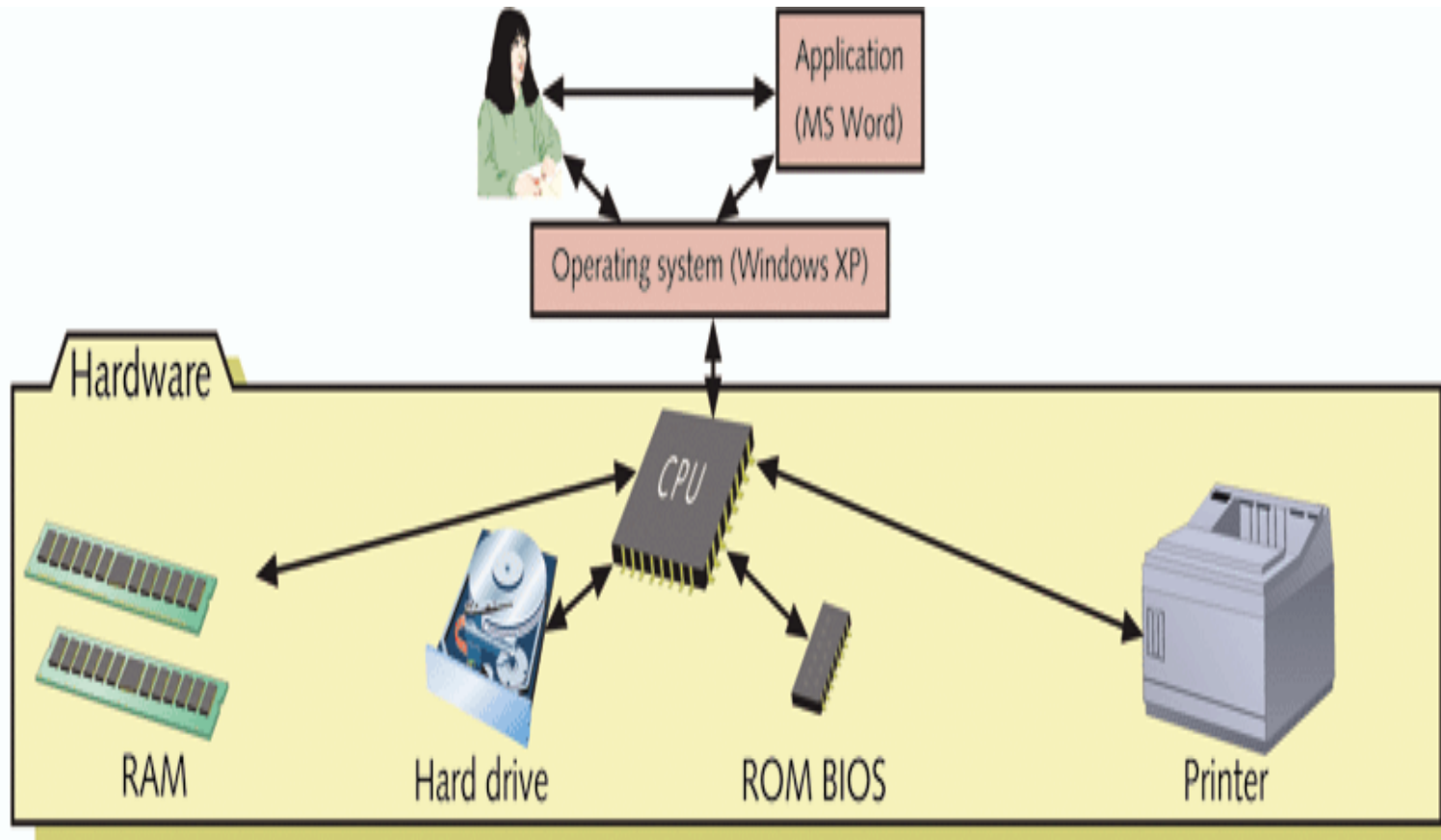

**Figure 2-1** Users and applications depend on the OS to relate to all hardware components

# The User's View







# What “is” an operating system?

Software files (programs) which are stored on the hard disk

- kernel with the internal programs
- external programs

## Supporting Data Files

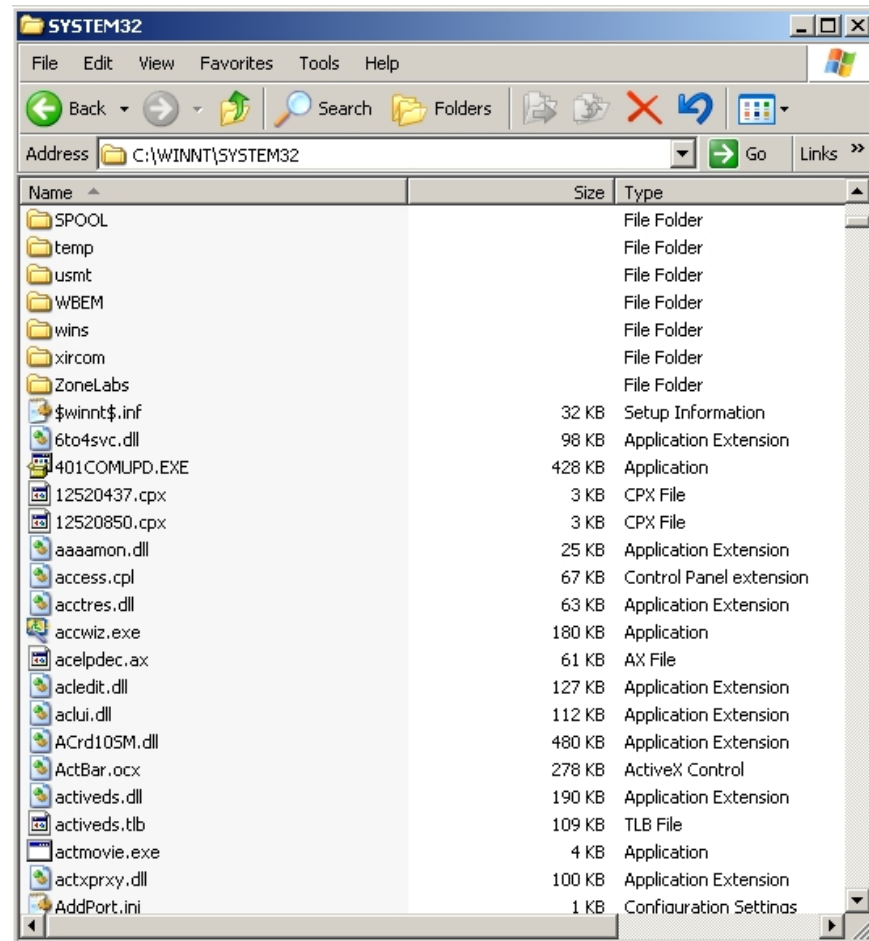

# The kernel

The operating system software file (program) which is **copied into RAM**, usually from the hard disk drive, during the **boot-up**.

The kernel remains in RAM while the computer is on and is **in charge of the overall operation** of the computer system.

The kernel contains the “**internal programs**” for the most often used operations like copying files.

- kmem (Linux)
- command.exe (Microsoft)



# Kernel

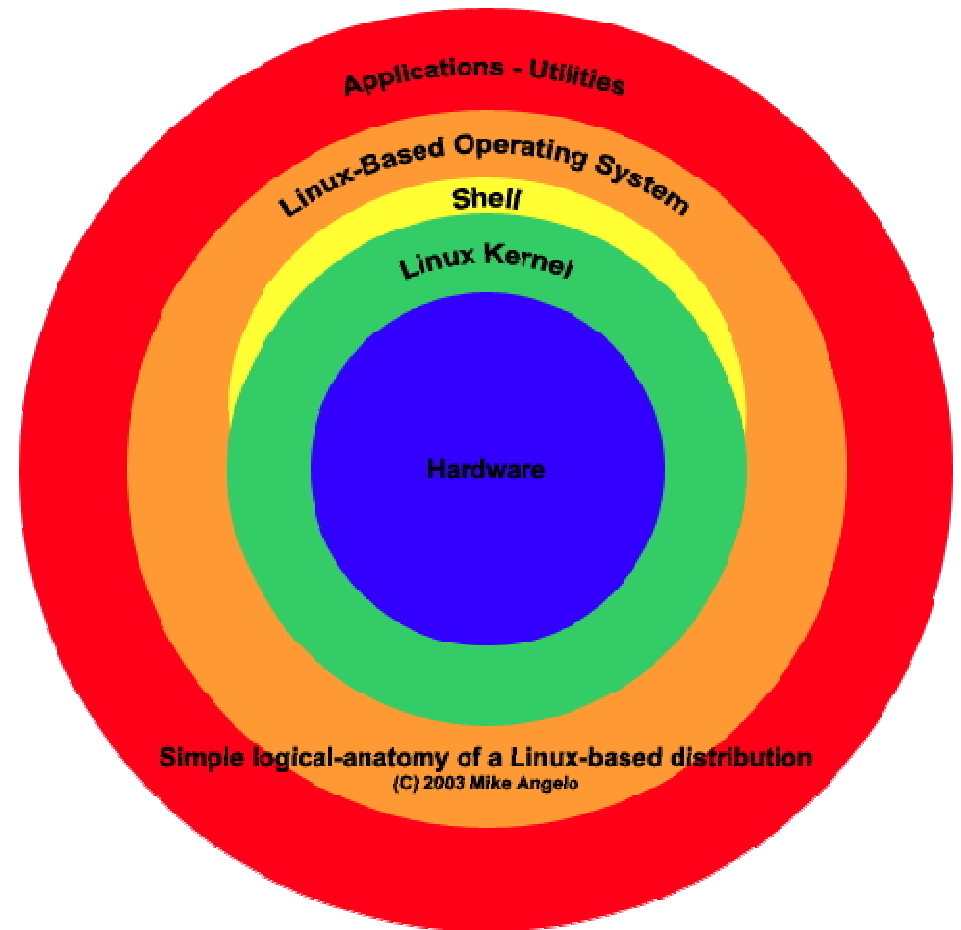

- **Kernel** – The internal part of the operating system.
  - Those software components that perform the basic functions required by the computer.
    - File management
    - Memory management (RAM)
    - Security

# The functions of an operating system

1. Manages and Interacts with Computer Hardware
2. Provides and Manages System Security
3. Provides the System Interface
4. Provides the Interface for Application Software

# 1. Manages and Interacts with Computer Hardware

- Manages the **CPU**
  - What software programs the CPU works on and when
- Manages **RAM**
  - What is stored in RAM and where it is stored
  - Virtual memory
  - OS will send message when RAM is full

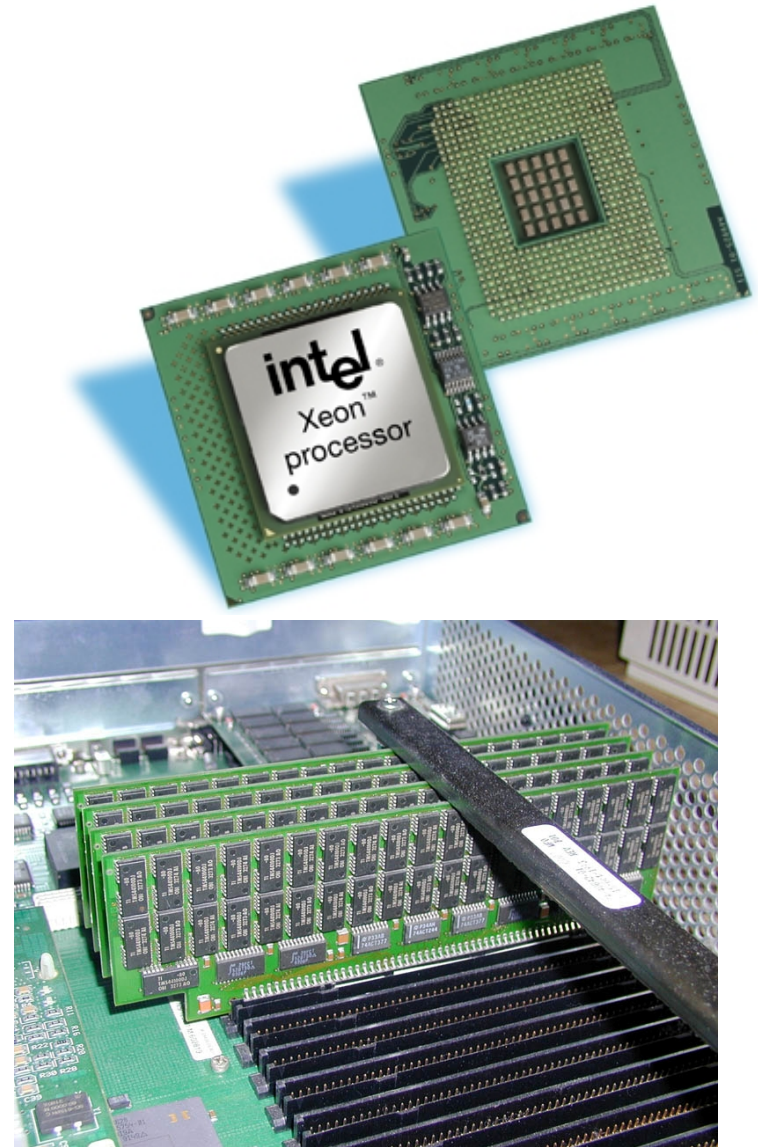

# 1. Manages and Interacts with Computer Hardware (continued)

- Provides the interface for **storage devices** and manages how data is stored on those devices
  - in charge of formatting disks
  - creates sectors and clusters
  - creates F.A.T. or V.T.O.C.
  - sends message when disk is full or there is some other problem with writing data to the disk
  - virtual memory
  - CD-ROM, DVD-ROM
  - Flash drive



# 1. Manages and Interacts with Computer Hardware (continued)

- Provides the Interface for **Input and Output Devices**
  - keyboard, mouse, printer,
  - **device drivers** = software programs which allow the hardware device to be used by the operating system and by application software

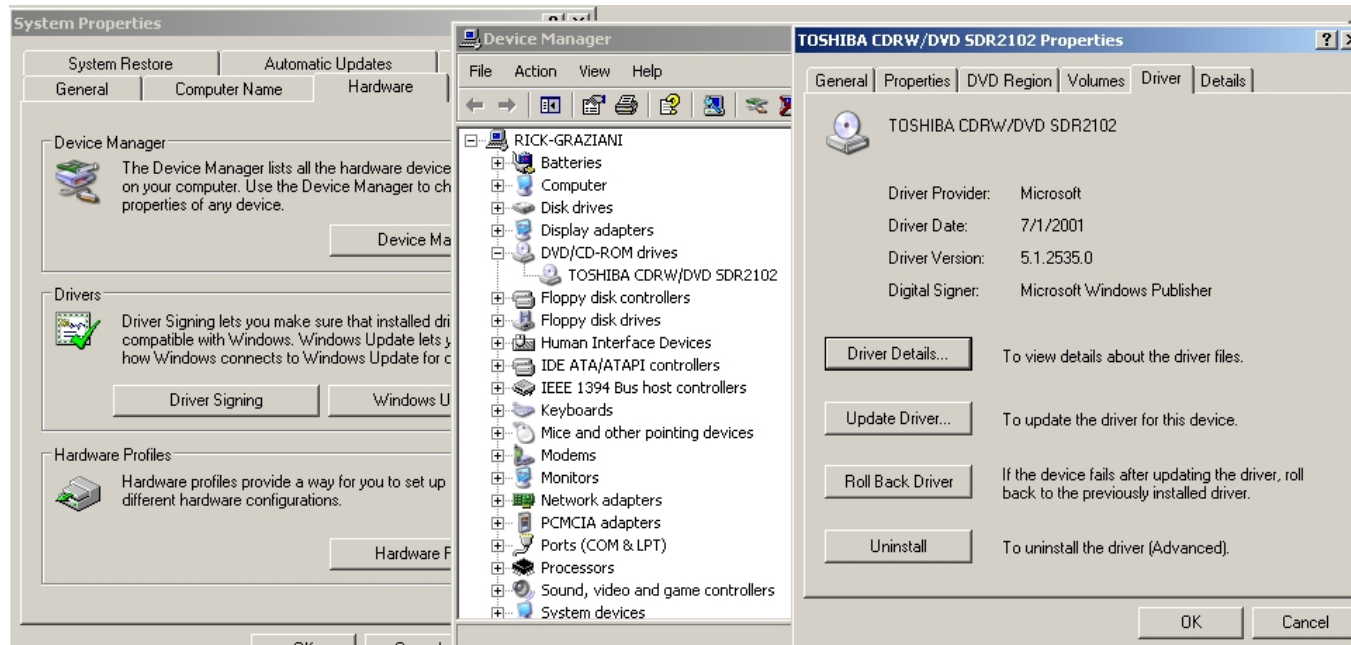



# Preemptive Multitasking vs Cooperative Multitasking

## Cooperative Multitasking

OS gives CPU processing time to other programs at a logical point, usually during idle time

## Preemptive Multitasking

OS allocates CPU time between the different programs based on amount of time and priority of the software application

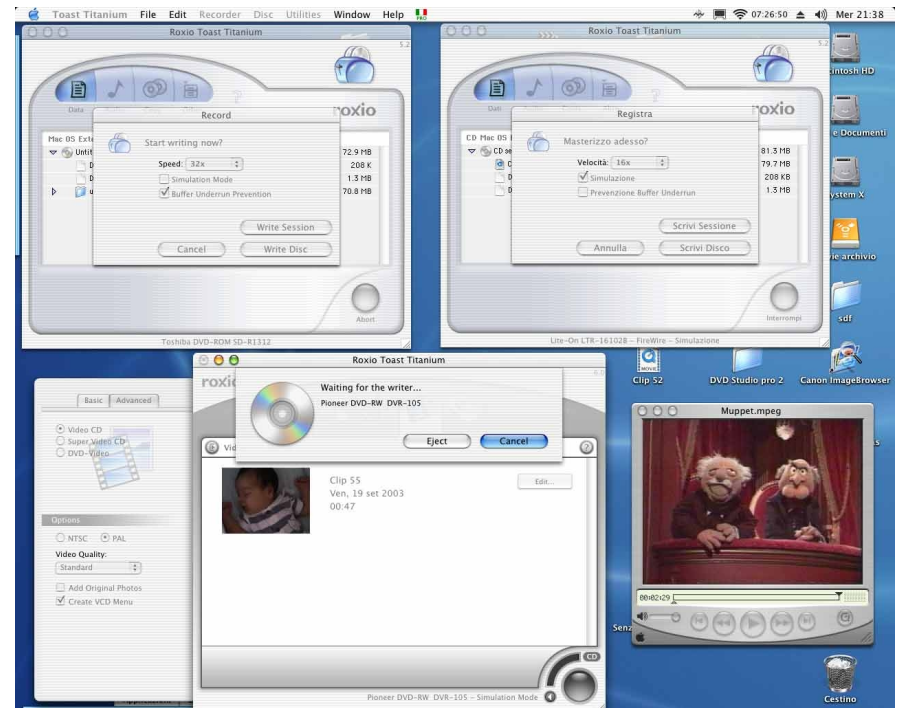

# Multiprocessing with Multiple CPU's

**Asymmetric Multiprocessing** = Tasks are assigned to a specific CPU and each CPU has its own RAM memory

**Symmetric Multiprocessing** = Tasks are assigned to any available CPU and CPU's can share RAM memory

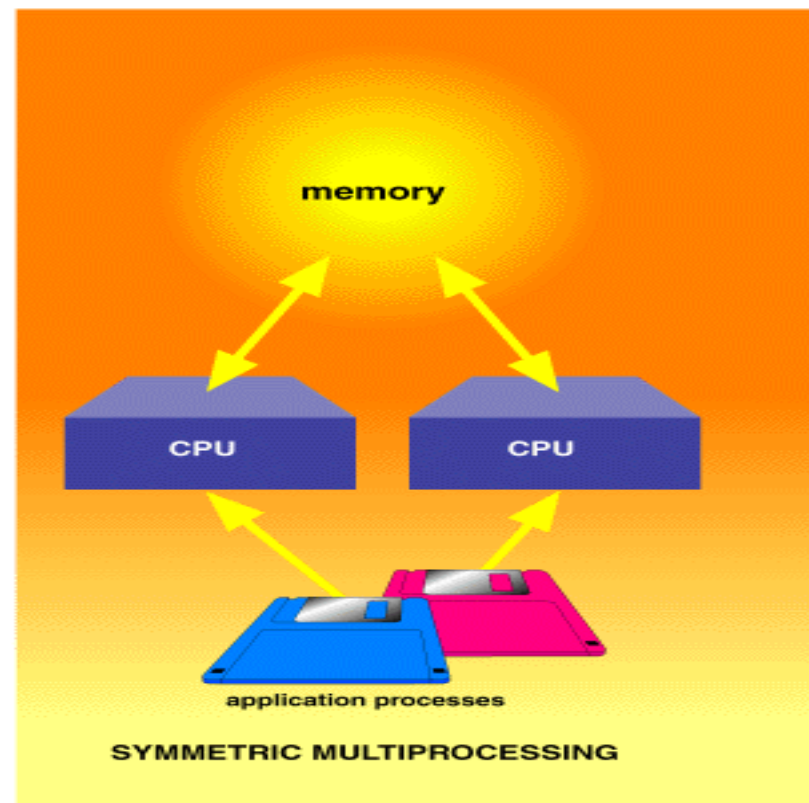
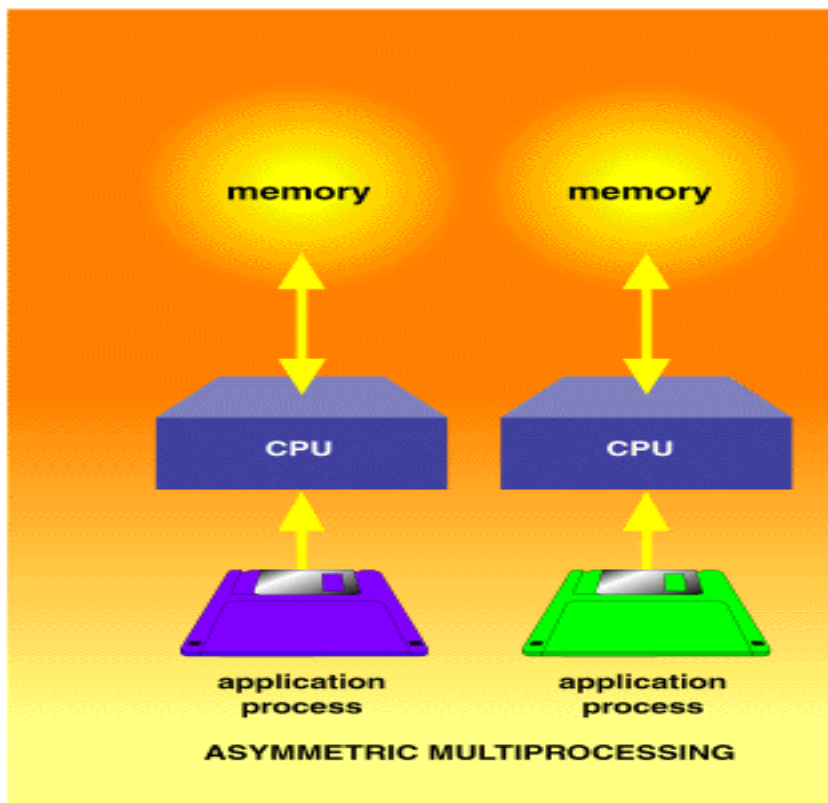

# Processes

- Scheduler – Maintains a record of the processes.**
  - Adds new processes when launched.
  - Removes old processes when completed.
  - Uses a process table.
- Process Table – Information about each process including:**
  - Main memory cells (RAM)
  - Priority
  - Running or waiting (input from user or saving to disk)

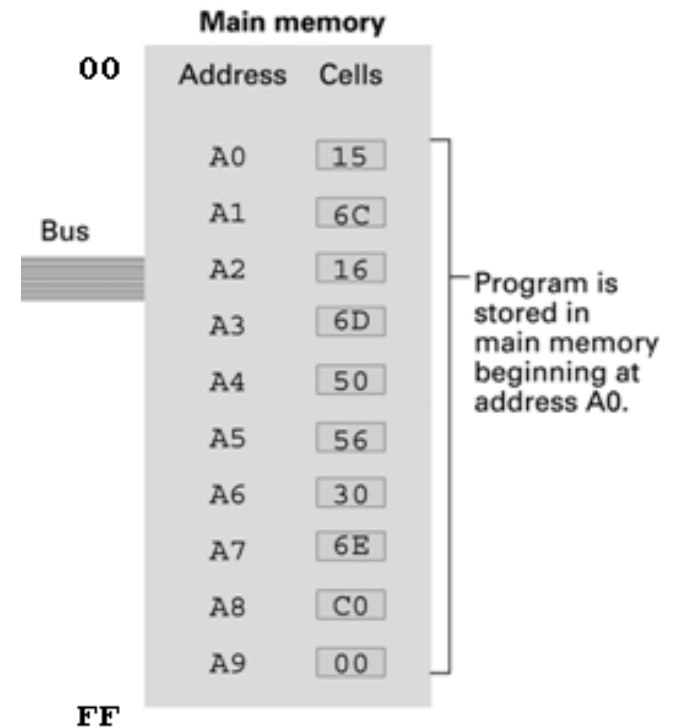
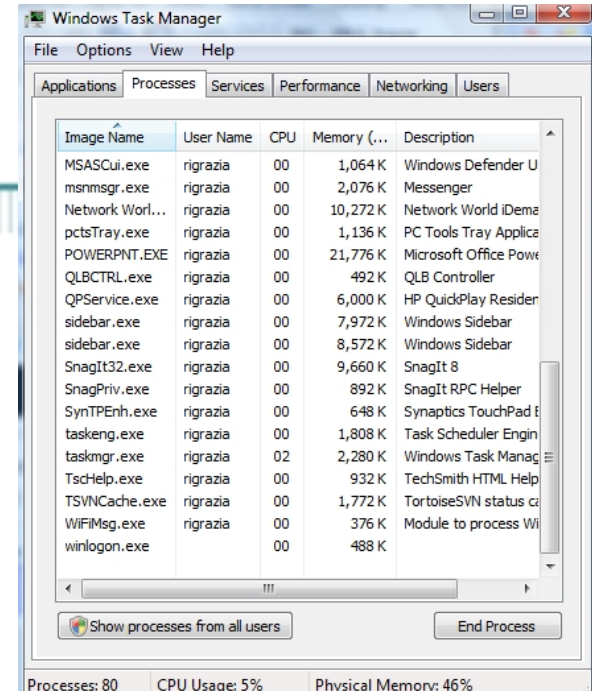

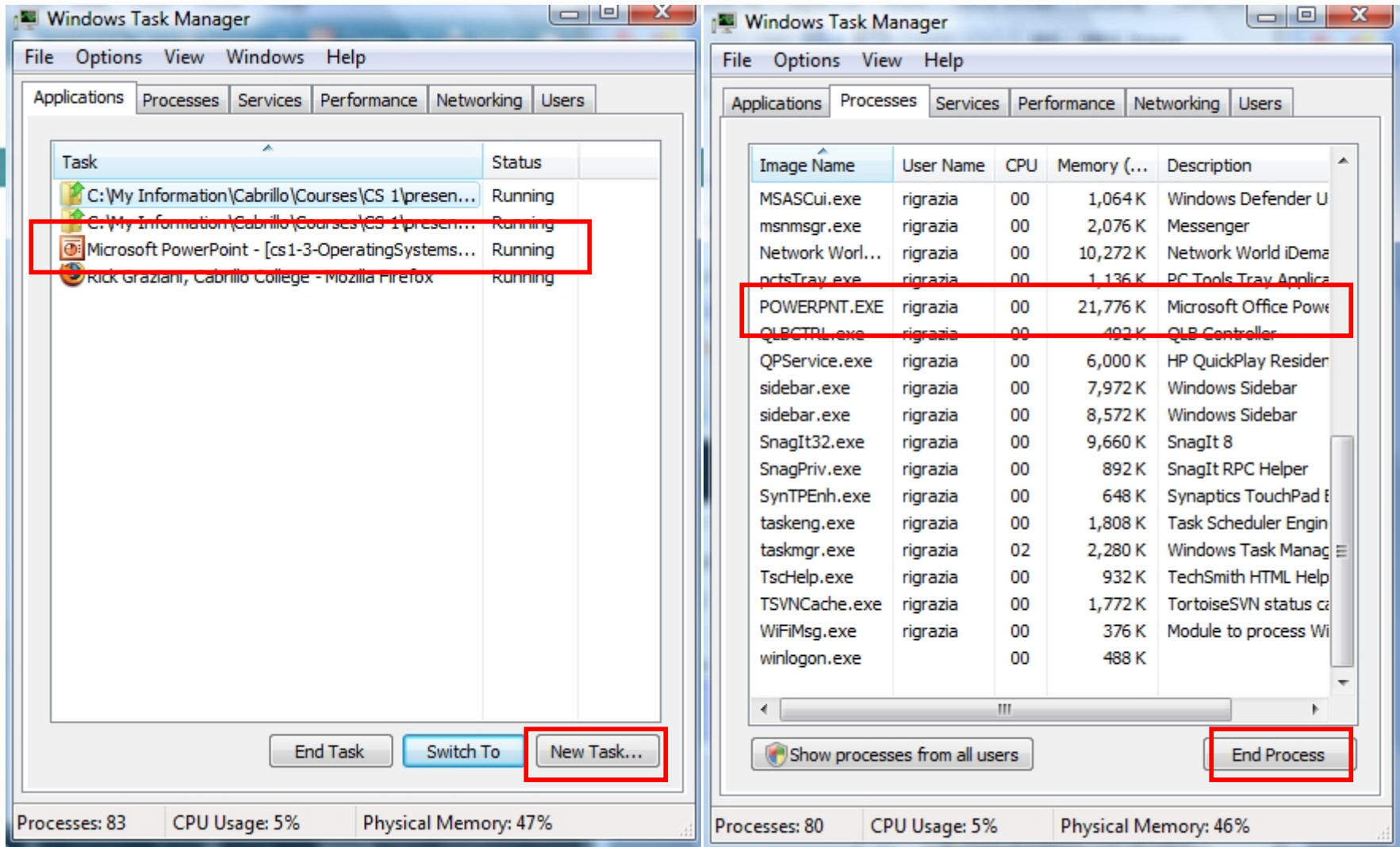

- Viewing processes with Microsoft Windows
- Task Bar – Right-click, Task Manager
- Ending a process – ***Killing the process***

# Processes

- **Dispatcher** - Oversees the execution of each process by the CPU.
  - Gives each process a time slice of CPU time.
  - Changes between processes.

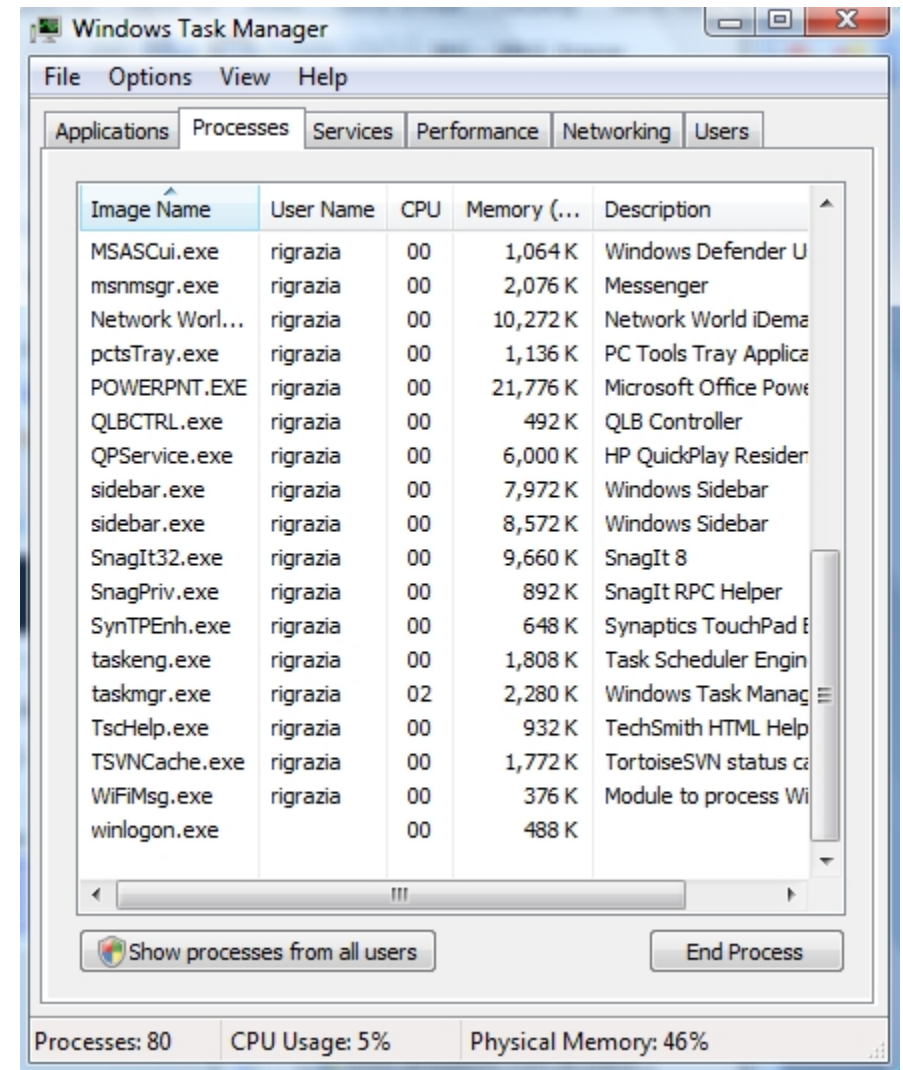

# Server (Multiuser) Operating Systems

- Found on mainframes, minicomputers and PCs
- **server** = a computer which processes information (CPU and RAM) , stores information (hard disk), and/or provides access to peripheral devices (printers) for multiple users
  - Email
  - Web
  - Gaming

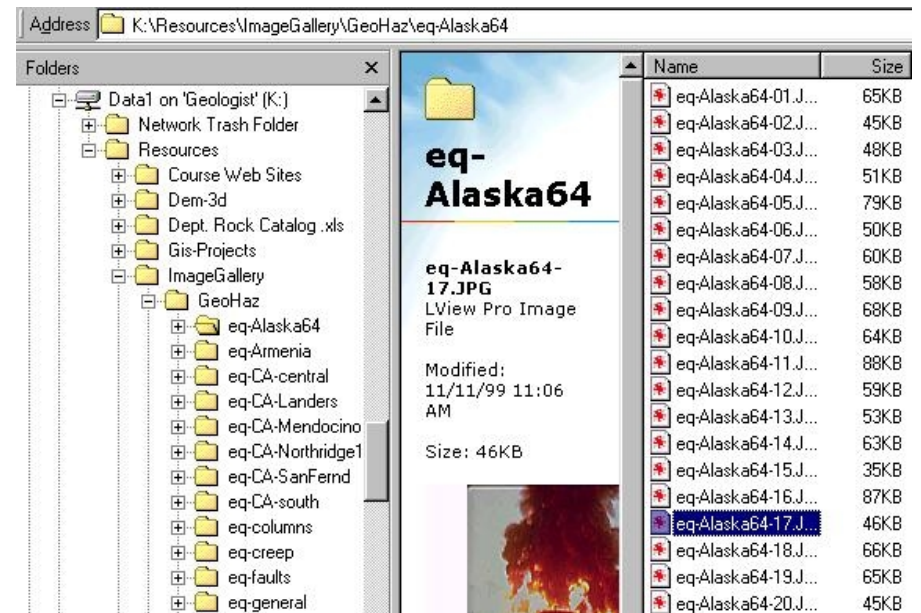

# Examples of Server Operating Systems

- MAC OS X Server
- Windows Server



# Advantages/Disadvantages of Server Operating Systems

## Advantages

- Central location for the installation and administration of all software and data
- More cost effective - less expensive than multiple computers (PCs, Macs)

## Disadvantages

- Single source for possible problems
- Loss of individual user control of their own software, data, and peripherals

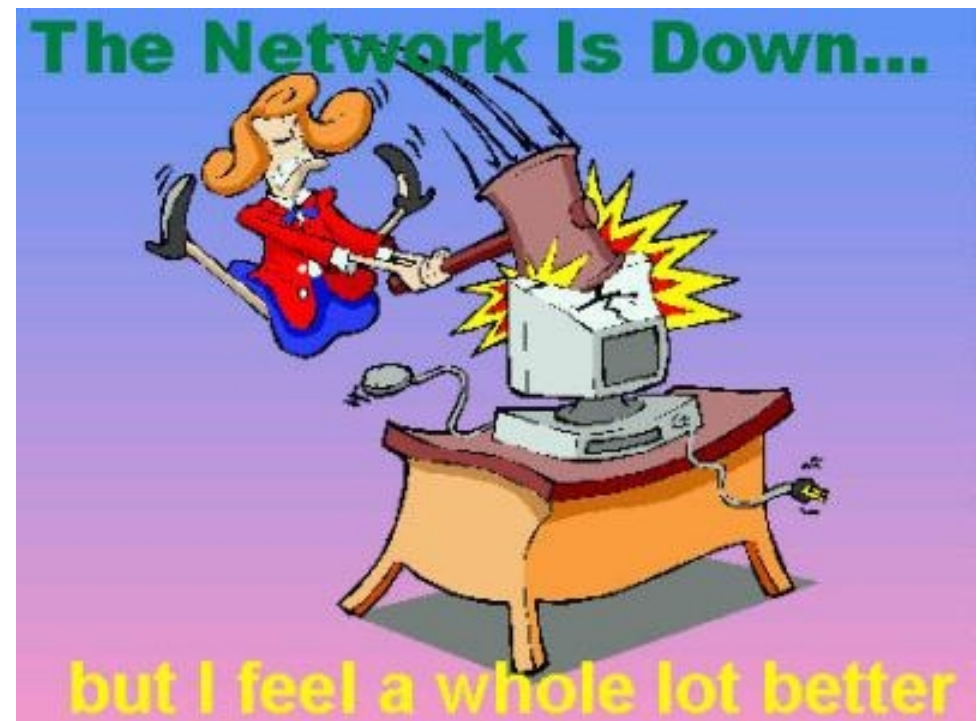



# Virtual Memory

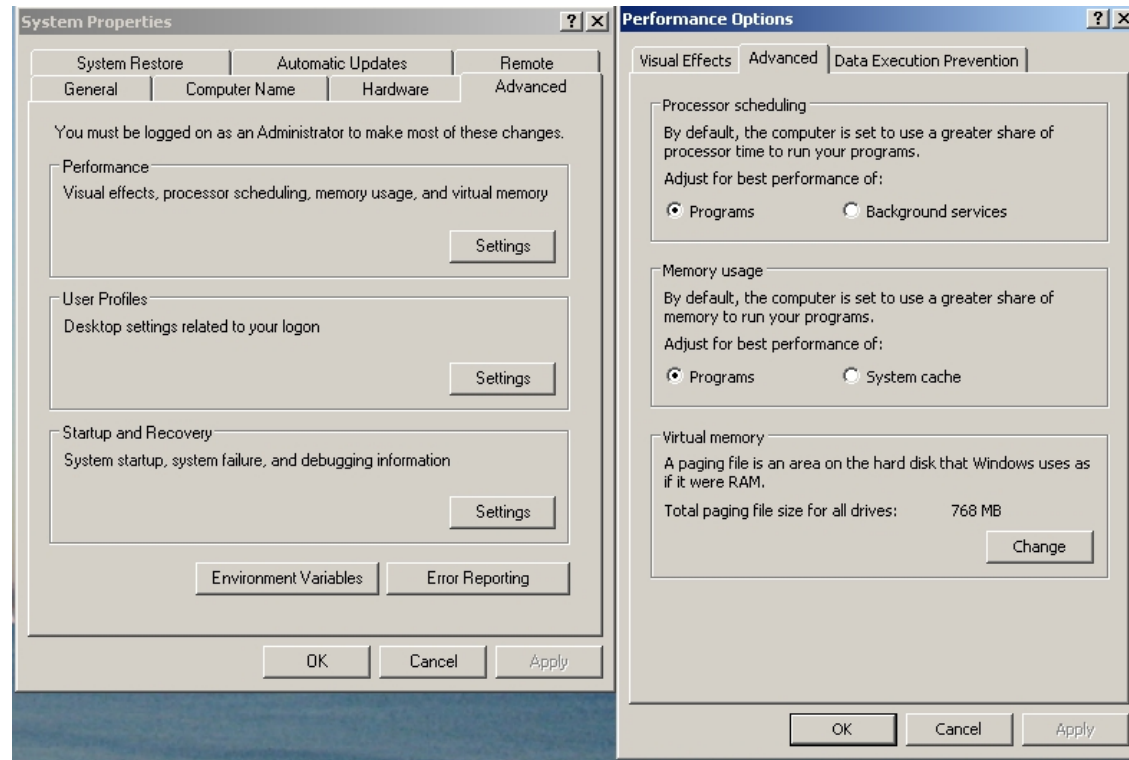

**Virtual Memory (VM)** = the ability of the CPU and the operating system software to use the hard disk drive as additional RAM when needed (safety net)

**Good** – no longer get “insufficient memory” error

**Bad** - performance is very slow when accessing VM

**Solution** = more RAM

# Virtual Memory

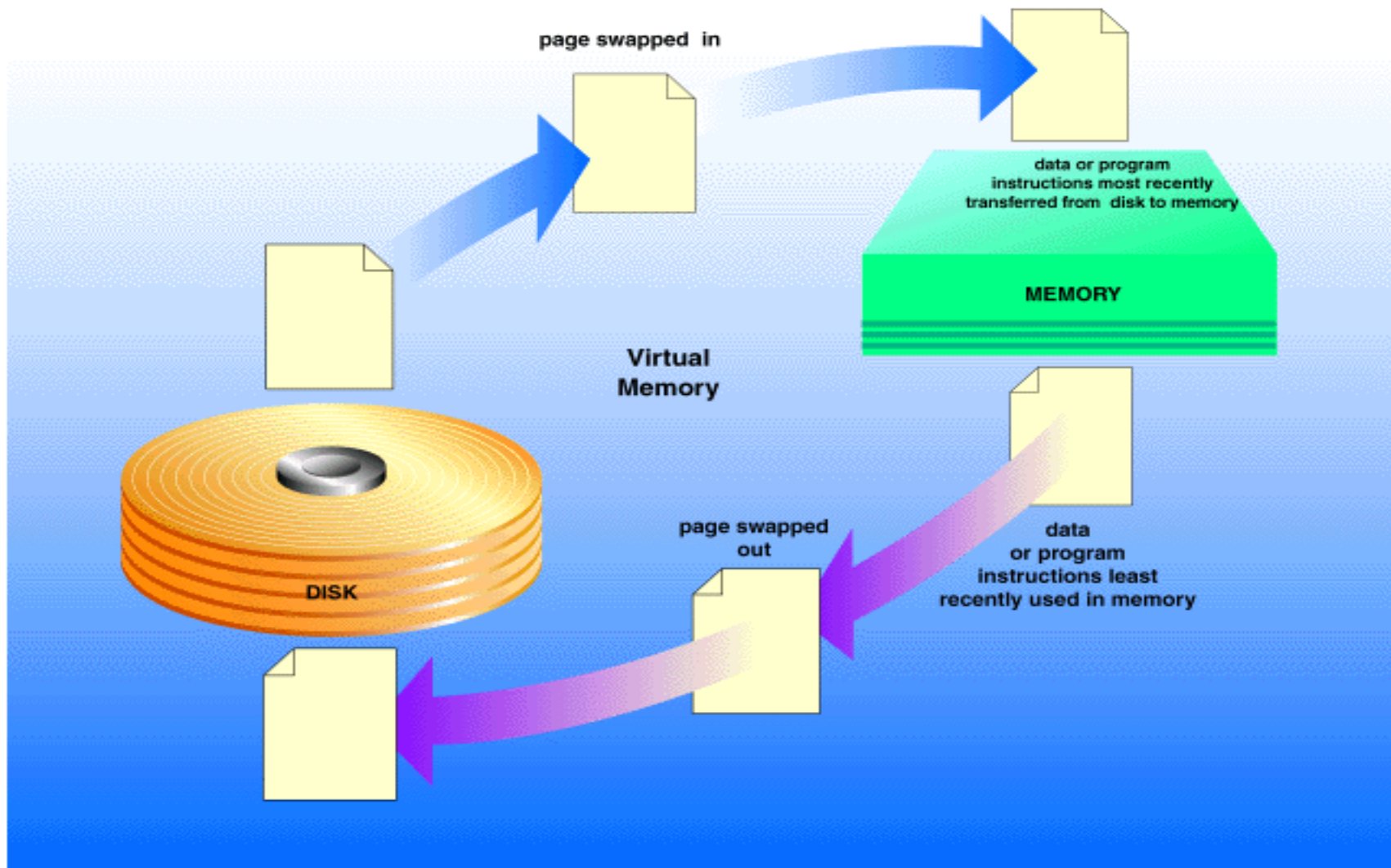

## 2. Provides and Manages System Security

### Single-user Operating Systems

- minimal security
- user has full authority

### Server Operating Systems

- login and password capability
- protection of user's data stored on the server's central hard disk drives
- protection and security for software programs



### 3. Provides the System Interface

**System Interface** or **shell** = the interface between the user and the computer

#### Command Line Interface (CLI)

- Linux, UNIX, DOS, older OS's

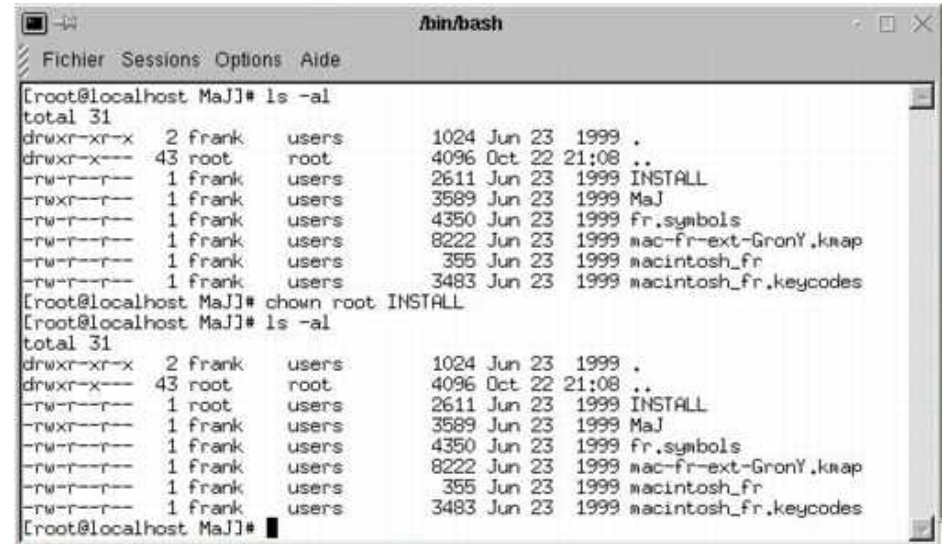

```
bin/bash
Fichier Sessions Options Aide
[root@localhost MaJ]# ls -al
total 31
drwxr-xr-x  2 frank  users   1024 Jun 23  1999 .
drwxr-x--- 43 root   root    4096 Oct 22  21:08 ..
-rw-r--r--  1 frank  users   2611 Jun 23  1999 INSTALL
-rwxr-x---  1 frank  users   3589 Jun 23  1999 MaJ
-rw-r--r--  1 frank  users   4350 Jun 23  1999 fr.symbols
-rw-r--r--  1 frank  users   8222 Jun 23  1999 mac-fr-ext-GronY.kmap
-rw-r--r--  1 frank  users    355 Jun 23  1999 macintosh_fr
-rw-r--r--  1 frank  users   3483 Jun 23  1999 macintosh_fr.keycodes
[root@localhost MaJ]# chown root INSTALL
[root@localhost MaJ]# ls -al
total 31
drwxr-xr-x  2 frank  users   1024 Jun 23  1999 .
drwxr-x--- 43 root   root    4096 Oct 22  21:08 ..
-rw-r--r--  1 root   users   2611 Jun 23  1999 INSTALL
-rwxr-x---  1 frank  users   3589 Jun 23  1999 MaJ
-rw-r--r--  1 frank  users   4350 Jun 23  1999 fr.symbols
-rw-r--r--  1 frank  users   8222 Jun 23  1999 mac-fr-ext-GronY.kmap
-rw-r--r--  1 frank  users    355 Jun 23  1999 macintosh_fr
-rw-r--r--  1 frank  users   3483 Jun 23  1999 macintosh_fr.keycodes
[root@localhost MaJ]#
```

#### Graphical User Interface (GUI)

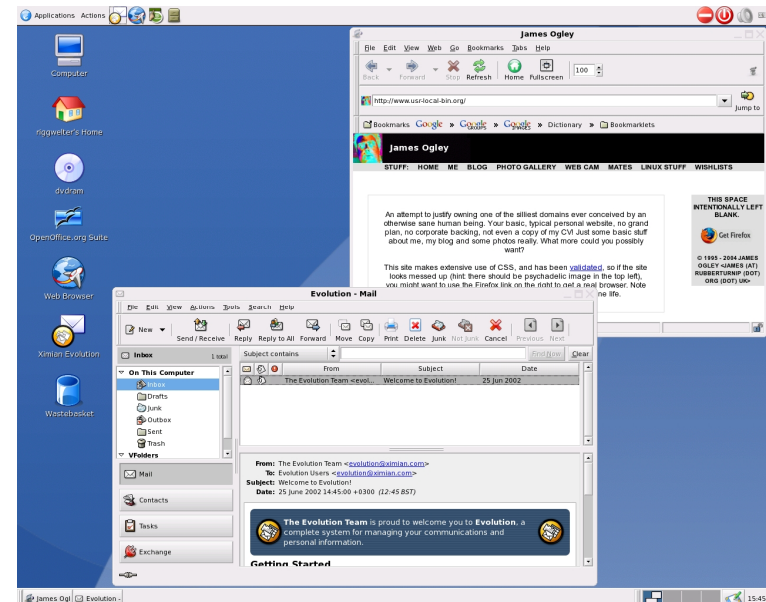

# Command Line Interface

## DOS, UNIX, others

```
Microsoft Windows XP [Version 5.1.2600]
(C) Copyright 1985-2001 Microsoft Corp.

C:\>copy a:\myfolder\budget.xls c:\accounting\newbudget2005.xlsx_

C:\>dir
Volume in drive C has no label.
Volume Serial Number is 3DB0-2A46

Directory of C:\

10/10/2001  06:41 AM    <DIR>          I386
10/10/2001  06:41 AM    <DIR>          BACKUP
10/10/2001  06:41 AM    <DIR>          WINNT
06/24/2004  12:53 PM                21 dv_trace.log
03/15/2002  08:02 PM                0 CONFIG.SYS
10/16/2001  11:58 AM    <DIR>          FOUND.000
12/17/2001  02:58 PM        76,080 comreads.dbg
12/17/2001  02:58 PM        72,909 comused.dbg
11/21/2001  04:41 PM    <DIR>          UPN304
06/04/2001  08:04 AM        245,814 mping.exe
10/10/2001  06:43 AM    <DIR>          DISCOVER
12/07/2001  11:14 AM    <DIR>          Cisco
01/01/2002  06:33 PM    <DIR>          BDE
11/19/2001  06:06 PM                0 AdobeWeb.log
12/06/2001  10:11 PM    <DIR>          Windows Update Setup Files
10/10/2001  06:41 AM    <DIR>          RECYCLED
```

# DOS plus Windows 3.1

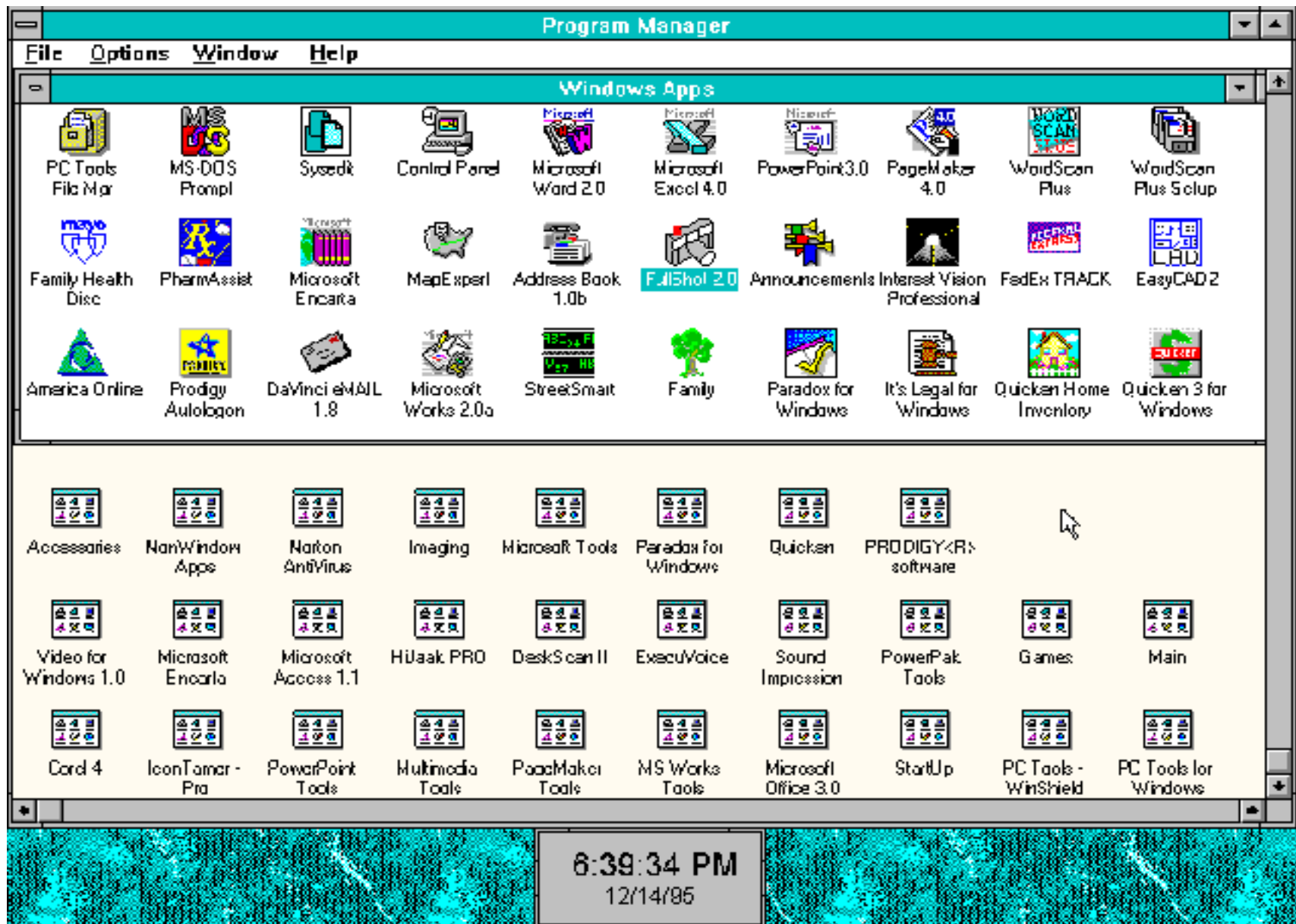

# Windows 95

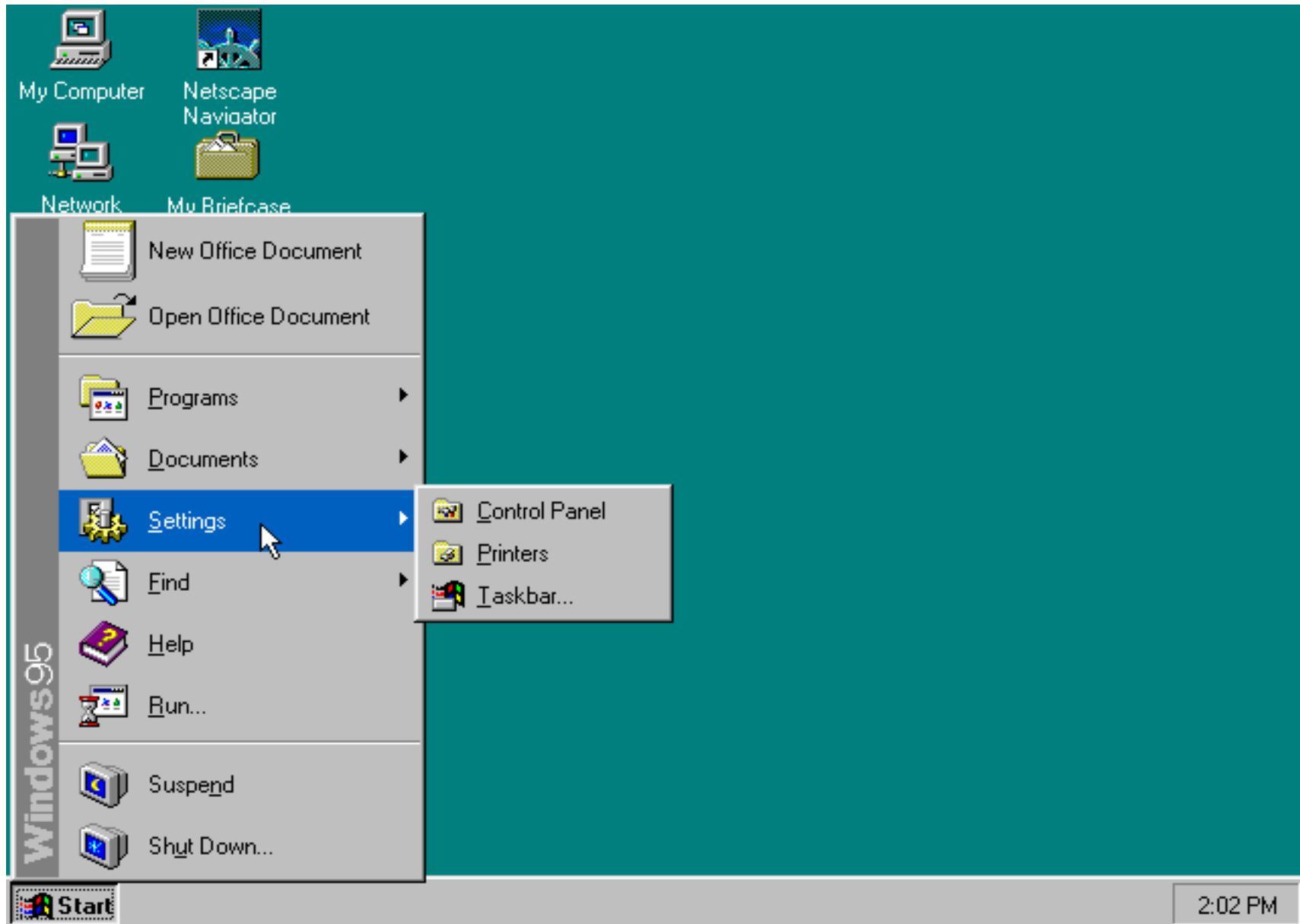

# Windows XP

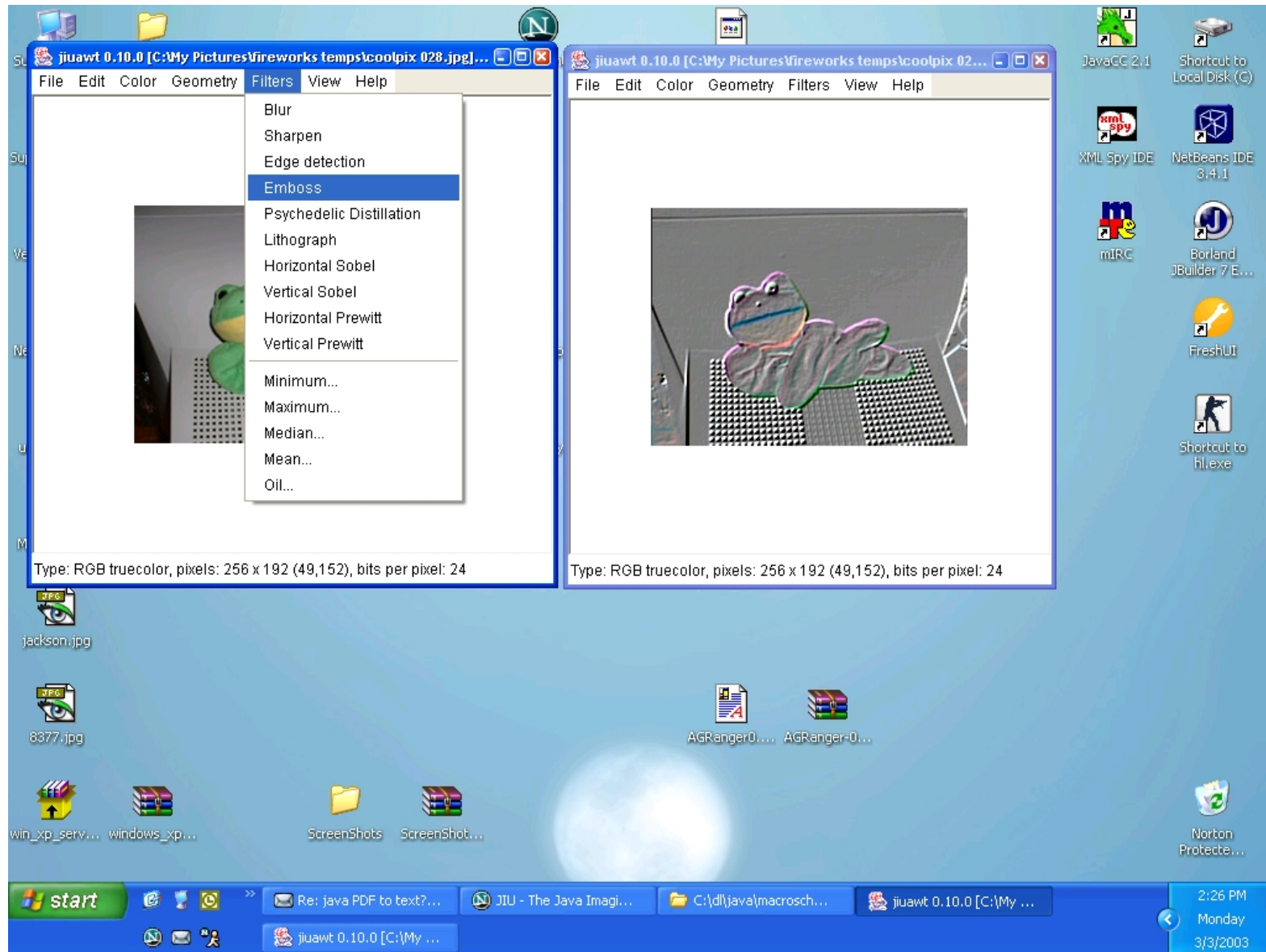



# Macintosh

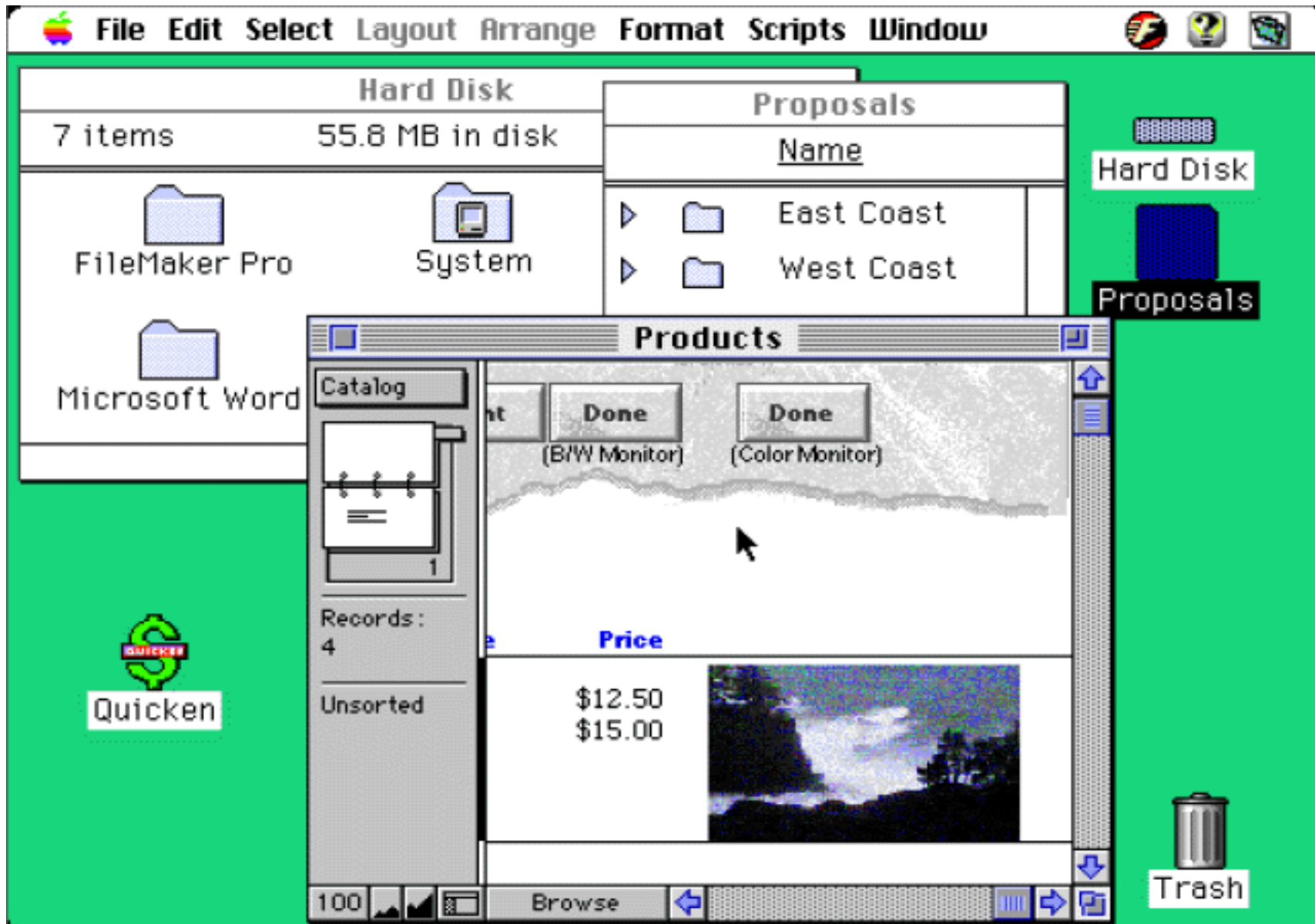

# Mac OS X

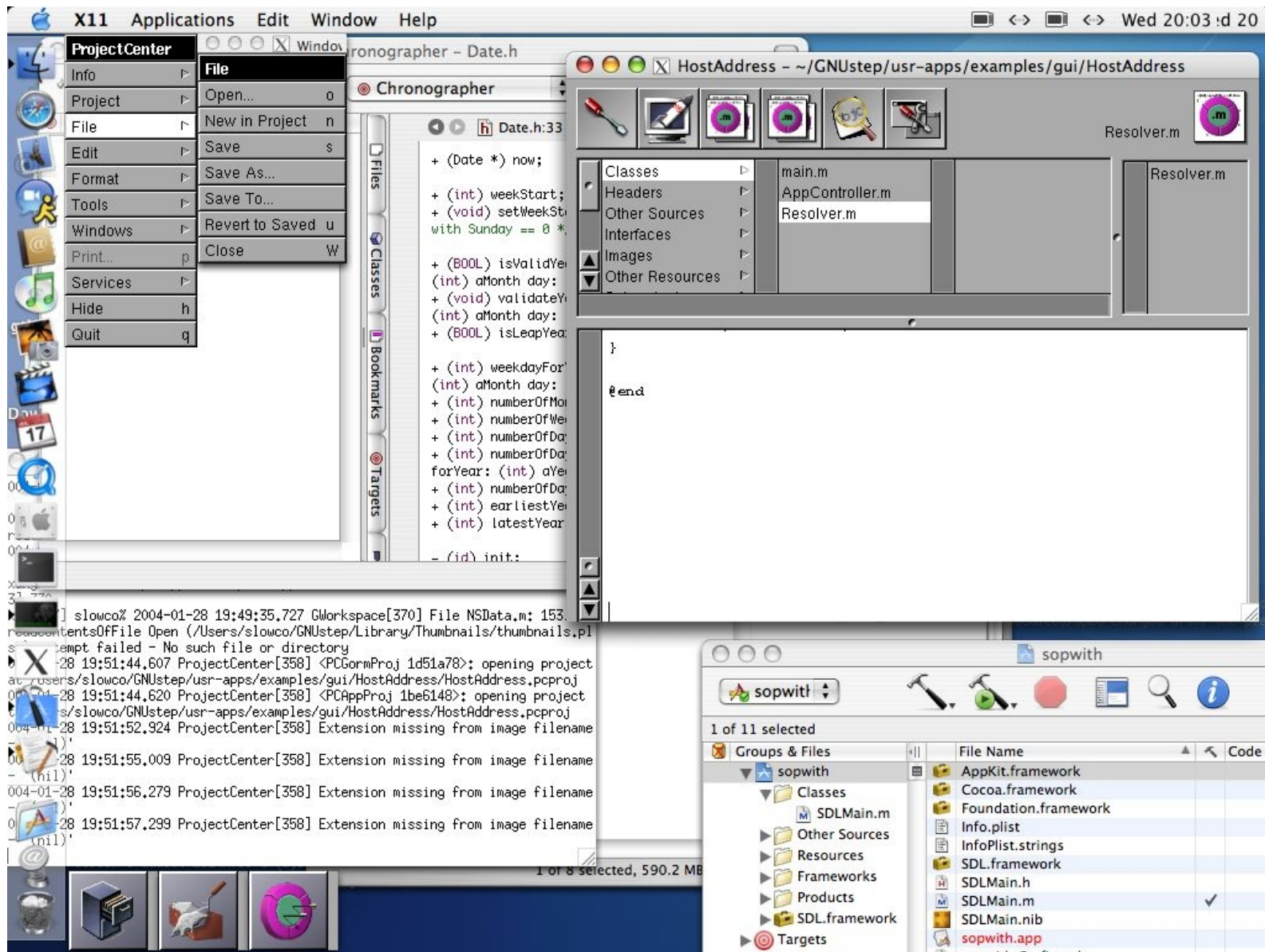

# UNIX with X-Windows

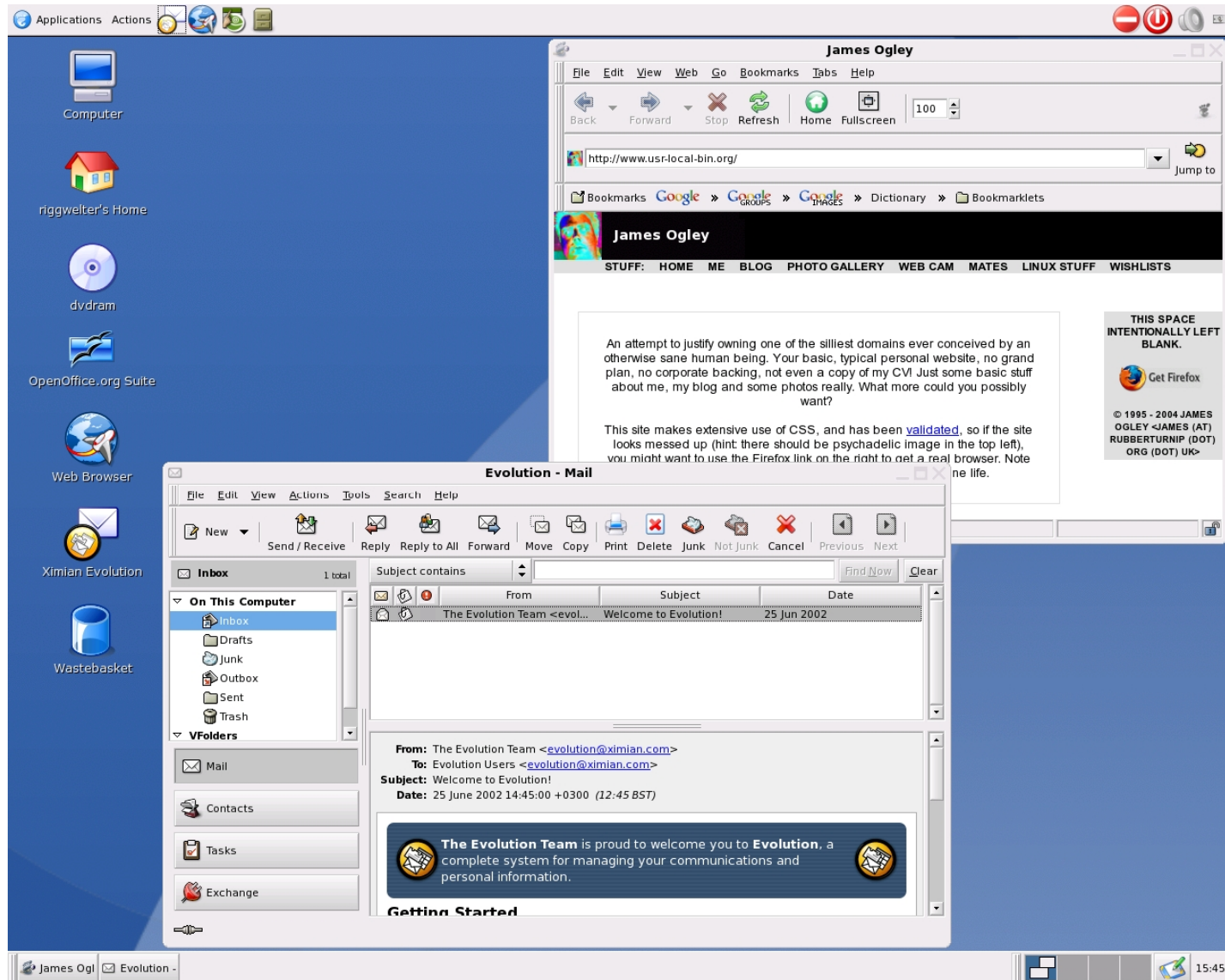

# Microsoft Windows 8



## 4. Provides the Interface for Application Software

- Operating systems are software
- Operating systems are designed and developed for a specific CPU or “family of CPUs”
  - **Macintosh OS:** Motorola 680xx, PowerPC Gx, Intel
  - **DOS:** Intel CPUs
  - **Windows 9x and XP:** Intel 80386, 80486, and Pentium CPUs
  - **Linux:** Intel CPUs
  - **MS NT & 2000:** Intel CPUs

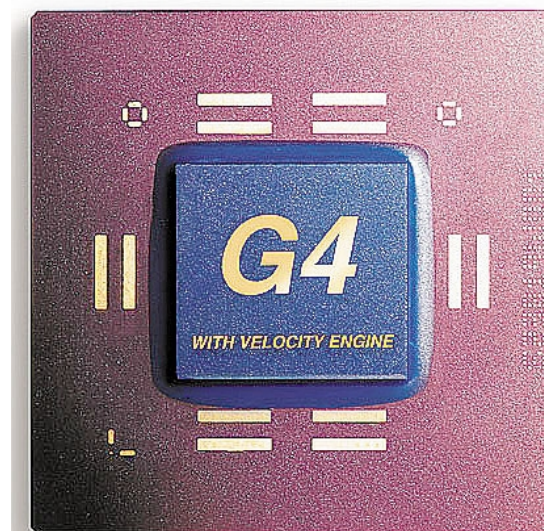
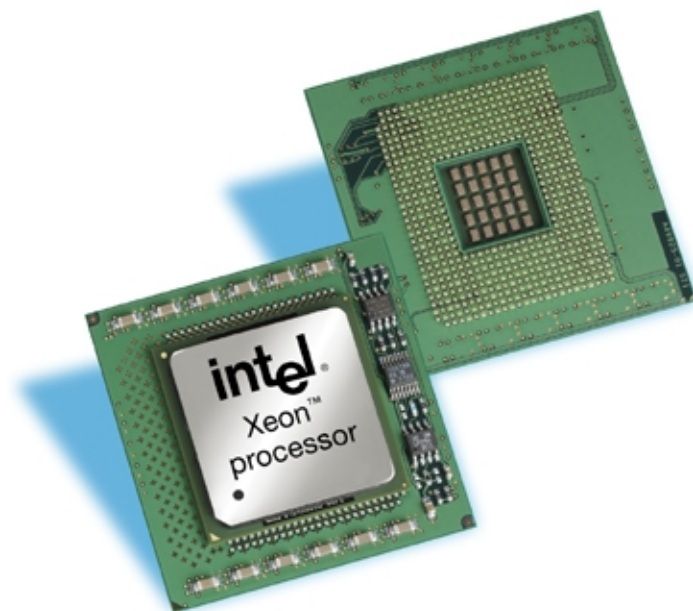

## 4. Provides the Interface for Application Software (continued)

- Application software is developed for an operating system

### MS Word for Windows XP

- Windows XP
- Intel CPU

### MS Word for the Macintosh

- Macintosh OS X
- Gx CPU or Intel CPU



# Compatibility

## Question

Will software developed for one operating system work on another?  
Will MS Word for Macintosh run on a PC with Windows XP?

## Answer

No (unless there is special emulation software or hardware). The software must be developed separately for each operating system.

Much of this is beginning to change with MAC using the Intel CPU.



# Order of Development

1. The CPU

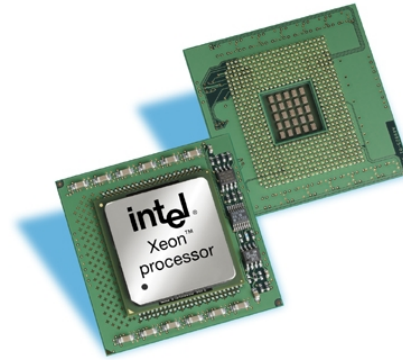

2. Other Hardware Components



3. Operating System Software

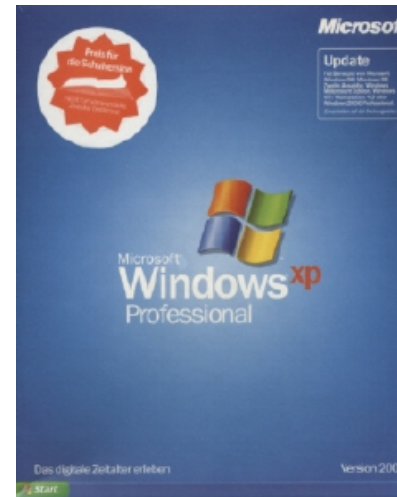

4. Application Software





# History of Operating Systems

## 1940's – 1950's

- Each program (**job**) required significant preparation of equipment.
  - Mounting tapes
  - Loading punch cards
- **Computer Operator** – Person who operated the computer.
  - Mount tapes
  - Load punch cards
  - Take printouts off of printer
- **Batch processing** – The execution of jobs by collecting them in a single batch, then executing them without further interaction with the user.

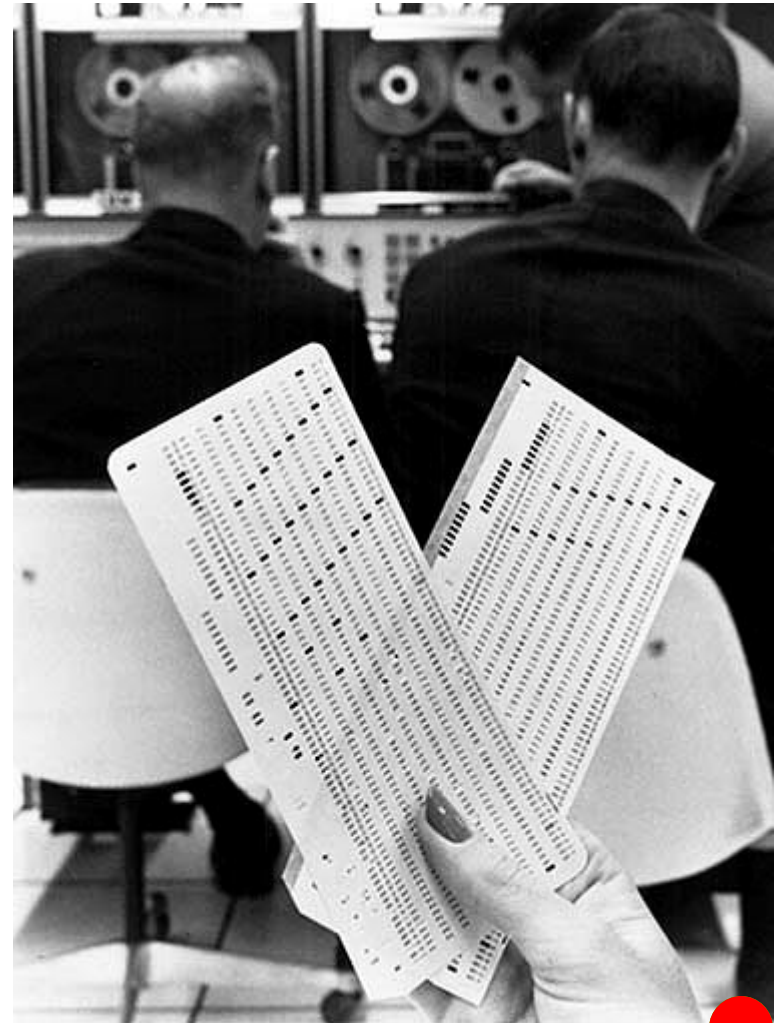

# History of Operating Systems

- **Job queue** – Jobs residing in mass storage (hard disk drives, tape) waiting for execution.
  - FIFO (First-In, First-Out)
  - Job Priorities and scheduling
- **Job Control Language (JCL)** – Set of instructions explaining the steps of a particular job.
  - Operating system sent these to the printer
  - Computer Operator follows the instructions



# History of Operating Systems

- **Disadvantage to Batch Processing**
  - No interaction with the user.
- Fine for software that does not need user interaction:
  - Payroll systems (creating checks)
  - Reporting systems
- Does not work well for other types of software:
  - Word processing
  - Reservation systems
  - Gaming



# History of Operating Systems

- Newer Operating Systems
- Used **remote terminals** and **interactive processing**
  - Computer must be fast enough to coordinate with the needs of the user.
- **Real-time processing** - Computer must execute tasks under a deadline.
- **Time sharing** – Provides service to multiple users at the same time.
  - **Multiprogramming** - Time divided into intervals.
- **Multitasking** – One user executing numerous tasks (programs) simultaneously

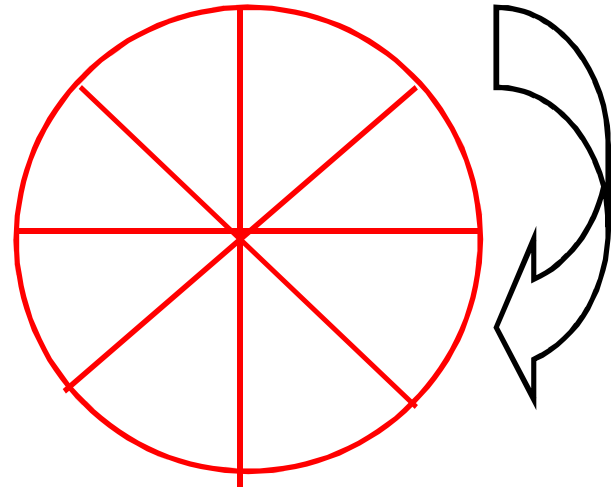

# Today's Operating Systems

- **Today's CPUs (multiprocessors)**
  - **Multiple processors**
  - **Load balancing**
    - Dynamically allocating tasks to the various processors so that all processors are used efficiently.
  - **Scaling**
    - Breaking tasks into a number of subtasks equal to the number of processors available.
  - **The Network (Internet)**
    - Becoming a single network-wide operating system rather than a network of individual operating systems.

